

Entanglement and non-classicality of generalized quantum optical vortex states

Anindya Banerji¹ *

Ravindra Pratap Singh² †

Abir Bandyopadhyay¹ ‡

¹ Hooghly Engineering and Technology College, Vivekananda Road, Pipulpati, Hooghly 712103

² Physical Research Laboratory, Navrangpura, Ahmedabad 380009

Abstract. The negativity of the Wigner function is discussed as a measure of the non classicality and the quantum interference pattern obtained therein as a possible measure of the entanglement between the two modes of the vortex states formed by photon subtraction from two mode squeezed vacuum. This measure of entanglement is compared with the results obtained from concurrence and log negativity.

Keywords: Entanglement, Wigner function, concurrence, quantum elliptical vortex

1 Introduction

Entanglement is a fundamental characteristic of quantum mechanics. It is this feature of quantum mechanics which is being increasingly studied and analyzed to achieve a variety of quantum phenomena like quantum teleportation [1] and quantum information processing [2]. In the not so distant future these emerging technologies will define how we communicate and compute. Photonic states of light are speculated to play an ever increasing role in this particular field [3]. It is therefore important to study the entanglement features of various such states of light which can be generated and put to use for a practical model of quantum information processing.

2 Formulation and results

In our present work we study the entanglement present in a class of generalized quantum optical vortex states [4]. The states that we consider here are engineered by subtraction of photons from one of the modes of the output of a type II spontaneous parametric down conversion. These states have the form

$$|\xi\rangle_k^{(s)} = \mathcal{A}_k b^k \exp(\xi a^\dagger b^\dagger - \xi^* ab) |0, 0\rangle \quad (1)$$

We call these two mode squeezed vortex (TMSV) states. The order of the vortex is determined by the difference in the number of photons between the two modes. If k photons are subtracted, the state, after some simplification, can be written as,

$$|\xi\rangle_k^{(s)} = \frac{e^{ik\theta}}{\cosh^2 r} a^{\dagger k} |\xi\rangle \quad (2)$$

An interesting property of the TMSV states is the appearance of the vortex structure in the quadrature space. The order of the vortex can be determined from the number of singular points in the phase plot [5]. It is interesting to note that the vortex structure in the quadrature distribution becomes less prominent with increasing order.

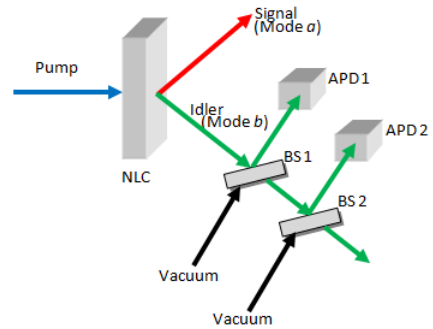

Figure 1: A schematic of the setup for producing TMSV state of order 2. Two 99% beam splitters (BS 1 and BS 2) are used for subtracting photons. NLC is a nonlinear crystal. SPDC generates the signal (mode a) and the idler (mode b). APD 1 and 2 are Avalanche Photo Diodes.

We use the Wigner function [6] to study the non classicality of this state. For the current state under study it can be written as

$$W(\tilde{\alpha}, \tilde{\beta}) = \frac{4}{\pi^2} (-1)^k \mathcal{L}_k [4|\tilde{\alpha}|^2] \exp \left[-2 \left(|\tilde{\alpha}|^2 + |\tilde{\beta}|^2 \right) \right], \quad (3)$$

where k is the number of photons subtracted. The presence of the negative regions is a signature of non classicality [7]. The cross correlator between different quadratures of two different modes show interesting quantum interference patterns. This can also be interpreted as a signature of entanglement. In support of this we study the entanglement present in this state with the help of logarithmic negativity [2, 8] and entanglement of formation [9, 10] or concurrence and compare the observations from the two approaches. The concurrence is a measure of the amount of entanglement needed to create the entangled state and defined as [11],

$$C(\rho) = \min_{p_i, \psi_i} \sum_i p_i E(|\psi_i\rangle\langle\psi_i|) \quad (4)$$

The minimization is taken over all possible decompositions of pure states ψ_i with probabilities p_i , which taken

*abanerji09@gmail.com

†rpsingh@prl.res.in

‡abir@hetc.ac.in

together reproduce the density matrix ρ of the given mixed state. On the other hand, $E(|\psi_i\rangle\langle\psi_i|)$ is the entropy of entanglement [12], commonly known as the von Neumann entropy [13], of the reduced density matrix. The von Neumann entropy is a well defined standard measure of pure state entanglement. For mixed states, it quantifies the amount of mixedness present between the constituent modes rather than the entanglement present between them.

We observe some surprising results when studying the logarithmic negativity and the concurrence. It was observed from our study of logarithmic negativity, that for two photon subtraction there was a very small rise in entanglement when compared to that of single photon subtraction. The entanglement falls sharply after reaching the peak. Further subtraction worsens the situation. However, our study of concurrence tells a different story. We observe that $C(\rho)$ increases with increase in r , the squeezing parameter. The rate of increase gradually slows down till it reaches the maximum value and then falls off rapidly to 0. It should be noticed that $C(\rho)$ attains its maximum value at $r \sim 2.1$. We infer that there exists an optimum value of the squeezing parameter which when applied at the beam splitter produces maximum entanglement of the two modes. As we move to higher orders of the vortex, the range of values of r which produces maximal entanglement, starts broadening. At $k=5$, there exists a well defined range of r that produces maximal entanglement of the two modes. The entanglement falls off rapidly on both the ends of this range. So we state that the TMSV states become maximally entangled mixed states (MEMS) for a particular value of the squeezing parameter. It would thus be interesting to compare the properties of these states with other MEMS in order to check the suitability for applications in the field of quantum information and computation.

Here we present an interpretation of the quantum interference patterns observed in our study of the cross correlations between different quadratures of the two different modes. It is observed that the interference is most prominent for $r = 2.1$. The interference effects decrease as we move away from $r = 2.1$ on either side which is exactly similar to what we obtained from the entanglement of formation. Broadening of the range of r which gives rise to a well defined interference fringe system with increase in the order of the vortex was also observed. Hence, we suggest that the quantum interference effects arising from the Wigner function of the cross correlation between different quadratures of the two modes can be interpreted as a signature of the entanglement present between the two modes. It is seen that the number of fringes as well as the volume of the fringes change with changing r . However, the maximum number of negative fringes is restricted by the order of the vortex. Since the negativity of the Wigner function is interpreted as a measure of non classicality, we suggest, the volume of the negative part of the quantum interference fringes might be a possible candidate for quantifying entanglement and

needs to be further studied.

For figures, a complete list of reference and a more technical description please refer to our work: <http://arxiv.org/abs/1304.2887>

References

- [1] C. H. Bennett, G. Brassard, C. Crepeau, R. Jozsa, A. Peres, W. Wootters, Phys. Rev. Lett. **70** (1993) 1895.
- [2] G. Vidal, R. F. Werner, Phys. Rev. A **65** (2002) 032314.
- [3] L. Allen *et al*, *Progress in Optics*, **39** ed. E. Wolf (1999) 291; J. Leach *et al*, Phys. Rev. Lett. **88** (2002) 257901; M. S. Soskin, M. V. Vasnetsov, *Progress in Optics* **41** ed. E. Wolf (2000) 219; D. G. Grier, Nature **424** (2003) 810; G. Gibson *et al*, Opt. Exp. **12** (2004) 5448; A. Mair *et al*, Nature **412** (2001) 313.
- [4] G. S. Agarwal, R. R. Puri, R. P. Singh, Phys. Rev. A **56** (1997) 4207; G. S. Agarwal, J. Banerji, J. Phys. A **39** (2006) 11503; A. Bandyopadhyay, R. P. Singh, Opt. Comm. **284** (2011) 256; G. S. Agarwal, New J. Phys. **13** (2011) 073008; A. K. Jha, G. S. Agarwal, R. W. Boyd, Phys. Rev. A **83** (2011) 053829; A. Banerji, P. K. Panigrahi, R.P. Singh, S. Chowdhury, A. Bandyopadhyay, J. Phys. A: Math. Theor. **46** (2013) 225303.
- [5] A. Banerji, R. P. Singh, A. Bandyopadhyay, arxiv:quant-ph/1304.2887.
- [6] E. P. Wigner, Phys. Rev. **40** 749 (1932).
- [7] A. Kenfack, K. Życzkowski, J. Opt. B: Q. Semiclass. Opt. **6** (2004) 396.
- [8] Życzkowski *et al*, Phys. Rev. A **58** (1998) 883.
- [9] C. H. Bennett *et al*, Phys. Rev. A **54** (1996) 3824.
- [10] W. Wootters, Phys. Rev. Lett. **80** (1998) 2245.
- [11] Tzu-Chieh Wei *et al*, Phys. Rev. A **67** (2003) 022110.
- [12] C. H. Bennett *et al*, Phys. Rev. A **53** (1996) 2046.
- [13] M. A. Nielson, I. L. Chuang, *Quantum Computation and Quantum Information*, Cambridge University Press, 2000.

Acknowledgment This work is partially supported by DST through SERB grant no.: SR/S2/LOP-0002/2011.